

SWINOMISH CRAB ABUNDANCE MONITORING PROGRAM LIGHT TRAP METHODS

Claire E. Cook, Sarah K. Grossman, and Julie S. Barber



A Swinomish Indian Tribal Community Contribution

SWIN-CR-2018-02

Original Publish Date: December 2018

Updated: December, 2023

La Conner, WA 98257

Table of Contents

Introduction.....	4
Methods	5
Design and construction.....	6
Deployment.....	6
Sample retrieval	6
Sample processing	7
Subsampling.....	8
Citizen scientist monitoring program.....	8
Step-by-step construction.....	9
Main body	9
Foam floats.....	9
Cod end	10
Light housing	11
Light unit.....	11
Acknowledgements.....	12
References.....	13
Appendix A: List of materials.....	15
Appendix B: Light trap monitoring datasheet.....	15
Appendix C: Citizen scientist step-by-step guide	18
Appendix D: Citizen scientist light trap report	20

Front cover photo: Claire E. Cook

List of Figures

Figure 1: Light trap diagram.....	5
Figure 2: Measurement locations for carapace width, carapace height, and total height on megalopae	6
Figure 3: Measurement locations for carapace width and height on juvenile instars	7
Figure 4: Main body of trap with holes drilled in the side and bottom.....	8
Figure 5: Main body of trap with foam float attached and cod end pieces staged for assembly	8
Figure 6: Fully assembled light trap	9
Figure 7: Light housing consisting of Pelican box, bulkhead fitting, and capped PVC pipe.....	9
Figure 8: Fully assembled light unit with 12V lithium-ion battery and programmable timer	10

SWINOMISH CRAB ABUNDANCE MONITORING PROGRAM

LIGHT TRAP METHODS

Claire E. Cook, Sarah K. Grossman*, and Julie S. Barber

Fisheries Department, Swinomish Indian Tribal Community, 11426 Moorage Way, La Conner WA, 98257

* Corresponding author: sgrossman@swinomish.nsn.us

INTRODUCTION

Many marine invertebrates and fishes use larval dispersal to reproduce. They have a two-phase life cycle in which planktonic larvae are dispersed in the water column before being transported to adequate rearing or settlement areas in nearshore environments (Pineda 1994, Cowen & Sponaugle 2009). For many marine broadcast spawners, the population dynamics of later life history stages are influenced by the recruitment and survival of pelagic developmental stages (Shanks 1983, Miller & Shanks 2004, Cowen & Sponaugle 2009). Thus, it is of particular interest to gain understanding of the role that larval processes play in determining community structure.

Larval phases of marine invertebrates and fishes have traditionally been sampled with discrete vertical or horizontal larval tows. Although these techniques are effective at catching early stage zoea, they have been shown to be less efficient at sampling strong-swimming and scarce organisms, specifically late-stage (megalopae) crustacean larvae (Hickford & Schiel 1999, Porter et al. 2008, Pineda et al. 2010). Additionally, larval tows are difficult to conduct in shallow nearshore environments and are limited in their ability to simultaneously sample across broad spatial and temporal scales.

These limitations led to the development of larval sampling devices called light traps. Light traps were originally designed to quantify the spatial and temporal patchiness in abundances of aquatic insects (Baylor & Smith 1953, Hungerford et al. 1955) and larval fishes (Faber 1981, Gregory & Powles 1985, Doherty 1987), but were soon adapted to study the larval abundances of a variety of marine invertebrates (McLeod & Costello 2017), including decapod crustaceans (Shanks & Roegner 2007, Herter & Eckert 2008, Sigurdsson et al. 2014). They function as active samplers and depend on the positive phototropism of organisms towards artificial illumination. They can be deployed throughout larval recruitment periods and are thus less affected by conditions that might temporarily affect larval distribution, such as wind and tidal forcing (Porter et al. 2008, Pineda et al. 2010, Sigurdsson et al. 2014). In particular, light traps have become a useful tool for studying recruitment dynamics of marine decapod crustaceans because of the high resolution temporal data and targeted sampling of late-stage (megalopal) larval abundance.

Most larval crab recruitment studies in the coastal waters of the west coast of the United States have focused on the commercially-important Dungeness crab (*Metacarcinus magister*). Monitoring larval recruitment of Dungeness crab with light traps has proven to be an effective method for discerning the relationship between settlement and oceanographic conditions, as well as the subsequent variation in commercial harvest in Oregon (Shanks & Roegner 2007, Shanks et al. 2010, Shanks 2013). Light trap research in Coos Bay, OR (Miller & Shanks 2004, Roegner et al. 2007), Willapa Bay, WA (Roegner et al. 2003), and Glacier Bay,

AK (Herter & Eckert 2008) has provided further evidence of the physical and oceanographic mechanisms that modulate Dungeness crab megalopal supply between coastal and estuarine environments.

Although larval dynamics of Dungeness crab on the Pacific coast have been well-studied, including light trap work, very little is known about larval crab dynamics in the inland waters of Washington State. The majority of work conducted on larval Dungeness crab in Washington has been limited to Grays Harbor and Willapa Bay, large coastal estuaries with markedly different oceanographic regimes than the southern Salish Sea. It remains unknown if these results are analogous to what occurs within southern Salish Sea populations, especially given the fact that distinctly different cohorts have been identified between coastal and Puget Sound populations (Dinnel et al. 1993, Jackson & O'Malley 2017).

The Swinomish Indian Tribal Community (SITC) Crab Abundance Monitoring Program (CAMP) seeks to fill extensive gaps in our knowledge of early life history phases of Dungeness crab in Washington's inland waters. Given these gaps, it is essential to develop a modern baseline of biological and physical metrics in the region so we can determine potential limitations to adult populations and assess the need for adaptive management through time. Thus, our program focused on collecting data on the megalopal and juvenile instar life history stages of this species using light traps and intertidal quadrat sampling, respectively.

This document is intended to provide standardized survey methods to potential collaborators throughout the monitoring network. Light trap catch efficiency has been shown to vary with light trap design, making it difficult to compare studies with different designs (Meekan et al. 2001). Consequently, it is critical that collaborators utilize a similar light trap design and survey methods. The SITC light trap design is modified from traps used successfully in larval crab research throughout coastal waters on the west coast of the United States, and has proven to be extremely efficient at sampling larval decapod crustaceans (Roegner et al. 2003, Miller & Shanks 2004, Herter & Eckert 2008).

SITC chooses to collect a variety of biometric and physical data (e.g., carapace dimensions, continuous salinity and temperature data) in addition to Dungeness crab megalopae and instar abundance. While these methods can easily be adapted to address a variety of research goals, at a minimum we ask that collaborators in the region collect data on Dungeness crab megalopae and instar abundances. Baseline data provided by this project will be crucial when examining whether fluctuations in adult Dungeness crab populations are due to limitations in habitat, larval supply, or because of other factors such as competition or density-dependent mortality. An increased understanding of these potential bottlenecks will inform prioritization of future restoration and management of Dungeness crab rearing habitat.

METHODS

Light traps are deployed at nearshore locations to evaluate ingress of larval Dungeness crab across Swinomish management regions. The traps are affixed to structures (e.g., dock, pier, or mooring ball) and float at the surface of the water throughout the Dungeness crab larval recruitment periods from April to mid-September. Samples are collected every one to two days and Dungeness crab larvae and juvenile instars are sorted from samples and enumerated. Instars are occasionally present in the light trap as a result of megalopae molting while in the trap. The duration of time that the light is programmed to be illuminated determines the hours that the trap is actively fishing. Results are standardized by catch per unit hour.

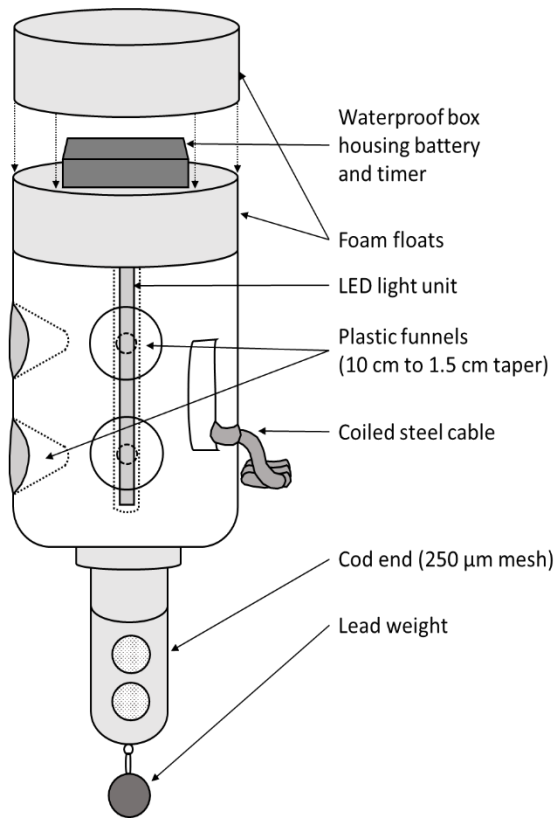

Figure 1. Light trap diagram. Trap includes six funnel openings and an LED lighting unit.

Design and construction

Light traps are constructed from 19 liter translucent plastic bottles (e.g., water bottles; Figure 1). Crab larvae gain entry through six translucent plastic funnels (10 cm to 1.5 cm taper) fitted into the main body of the trap. Illumination is provided by LED light strips (see Appendix A for a list of materials) powered by a 12 volt rechargeable lithium-ion battery and sealed in a waterproof housing. A timer is programmed to turn the lighting unit on at sunset and off at sunrise (rounded to the nearest half-hour). An 11 Ah battery is used to power the lighting unit for one or two-night deployments. Batteries are changed every one to two days to ensure constant illumination during the night. The bottom of the trap is capped with a removable PVC cod end fitted with 250 µm mesh. Foam floats ensure that the trap floats at the surface of the water and weights attached to the bottom of the cod end maintain the trap in an upright position.

Deployment

Light traps are moored from docks in at least 1.5 meters of water to allow the trap to float freely in extreme low tides. A coiled steel cable is used to attach the trap to a

dock or piling via the plastic handle on the translucent plastic bottle. A second line is attached to the plastic handle on the bottle and secured to a dock cleat, collar, or other feature using a stainless steel carabiner. The second line puts tension on the coiled steel cable and allows the trap to be positioned away from the dock. Buoys float the trap vertically in the water column with the entrance funnels within 1 m of the surface. Each trap lighting unit is equipped with a fully-charged battery and the timer is manually programmed to turn the LED light on at sunset and off at sunrise. Water movement through the funnel openings allows fishes and invertebrates to stay alive until they are removed from the trap the following day.

Sample retrieval

Securing lines are removed from the supports and the trap is pulled onto the dock, being careful to maintain its vertical position. As the trap is pulled from the water, the contents are filtered through the mesh and concentrated in the cod end. Once on the dock, the lid is removed from the top of the trap and the waterproof lighting unit is removed. Local seawater is used to rinse any remaining organisms into the cod end. The cod end is removed and its contents are transferred to a tub for processing.

Dungeness crab larvae and instars are sorted from the sample and enumerated. Carapace width, carapace height, and total height of a subset of 30 Dungeness crab megalopae and 30 instars are measured and recorded each week (Figures 2 and 3). Measurements can be taken in the field once one is familiar with species identification and measurement protocol (see **Sample processing** section). Other species of interest are recorded and, when possible, enumerated. If species cannot be identified or counted at the field site,

they can either be transferred to plastic jars and kept on ice or frozen until laboratory processing or preserved in 95% non-denatured ethanol for future verification and quality control measures. The rest of the organisms can be returned to the water once they have been counted and recorded. A fully charged battery is traded for the existing battery in the waterproof lighting unit. The lighting unit is re-installed and the lid is reattached to the trap. The trap is secured to the dock and the time of deployment is recorded.

Physical and environmental data are recorded in addition to counts of Dungeness crab megalopae and instars and other species of interest. Information on weather and current conditions are useful when considering the physical drivers of larval pulses. It is also important to record any complications with the trap, as this information can help determine the quality of the data collected. For instance, SITC staff note the level of charge on the existing battery in order to determine if the light turned on and the trap indeed fished overnight. An example of our light trap monitoring datasheet is included in Appendix B.

Sample processing

Larval crab species common to Puget Sound can be identified using *An Identification Guide to the Larval Marine Invertebrates of the Pacific Northwest* (Shanks 2001) and *Dynamics of Crab Larvae (Anomura, Brachyura) Off the Central Oregon Coast, 1969-1971* (Lough 1975). Poole (1966) provides a detailed description of larval stages of laboratory-reared *M. magister*. Distinguishing characteristics of *M. magister*, *Glebocarcinus oregonensis*, and *Cancer productus* can be found in DeBrosse et al. (1989, 1990).

Measurements of carapace width, carapace height, and total height are measured using a metric dial caliper (precision, 0.1mm) each week on a subset of 30 Dungeness crab megalopae and 30 juvenile instars per

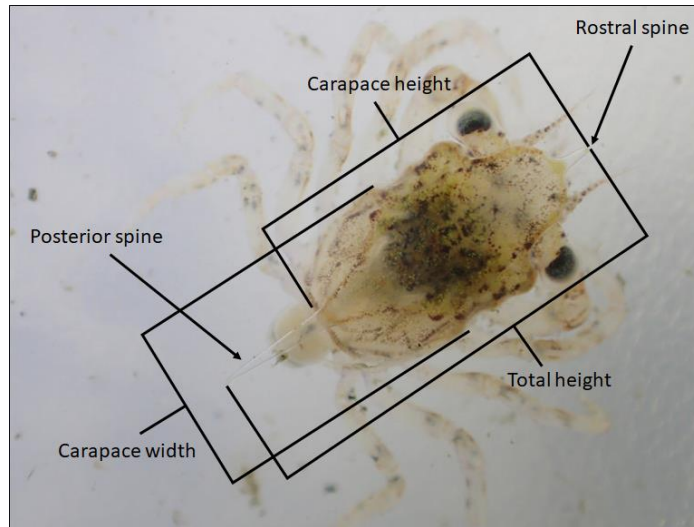

Figure 2. Measurement locations for carapace width, carapace height, and total height on megalopae.

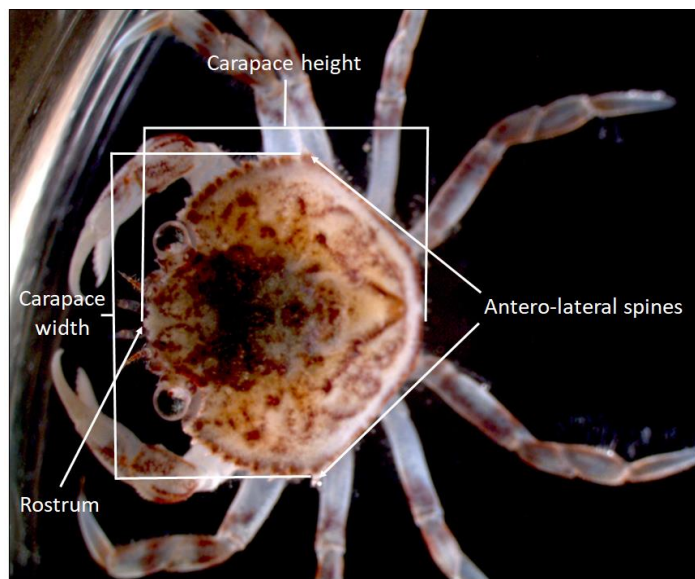

Figure 3. Measurement locations for carapace width and height on juvenile instars.

site. Carapace width and height metrics can offer important insights into the potential cohort-of-origin and the physical rearing conditions experienced by individuals (Dinnel et al. 1993).

Megalopa carapace width is measured at the widest point of the carapace while carapace height is measured from the back of the carapace to the tip of the rostral spine with calipers (Figure 2). Total height is measured from the rostral spine to the posterior spine and is only collected on megalopae (Figure 2). Instar carapace width is measured anterior of the 10th antero-lateral spines, while carapace height is measured from the back of the carapace to the tip of the rostrum (Figure 3).

Subsampling

Subsampling to estimate larval abundance is necessary if the Dungeness crab megalopae appear to be too numerous to count (>1,000 megalopae). Some choose to subsample by mass (Shanks et al. 2010), but for the purposes of this program, it was determined that subsampling by volume was more efficient.

To subsample by volume, first dilute the sample to a known volume using a large graduated vessel (e.g. 4L graduated bucket). Thoroughly mix to homogenize the sample and transfer triplicate aliquots (e.g. 200 mL) into sorting tubs to be enumerated. Count and record the number of Dungeness crab and other species of interest in each of the three subsamples. Determine the average count per subsample volume and ensure that each of the subsample counts are within 90% of the average. If they are not, transfer and count additional subsamples until they fall within the 90% range. Once the subsamples meet the criteria, multiply the average number of crab per subsample volume by the total sample volume to get an estimate of the total number of crab in the sample. An example of a table used to estimate larval abundance via subsampling can be found on the second page of the light trap monitoring datasheet in Appendix B.

Citizen scientist monitoring program

Continuous deployment of the light traps throughout the Dungeness crab larval recruitment period (April to mid-September) requires the traps be checked and the batteries changed at least every two days. This is an intensive time commitment and would not be possible without the help of citizen scientist volunteers.

Teams of volunteers adopt a light trap and collect the sample every Saturday. Each team is given a clipboard and datasheet, sample processing tub, sample collection jars, and a two-day battery and wall charger. They are instructed to check the trap at any point one day a week, take note of the remaining charge on the used battery, trade the existing battery for a fully charged battery, and collect any crab megalopae or instars that are present in the sample. Volunteers keep the samples in their freezers and SITC staff collect them every few weeks. Some volunteers are comfortable identifying and sorting the Dungeness crab megalopae from the other species present, while others prefer to collect all the megalopae and allow SITC staff to sort and count the Dungeness crab at a later date. To date, there have been no issues identifying crab to the species level in the frozen samples.

Volunteer support materials, including a step-by-step guide to checking light traps and the citizen scientist light trap report, can be found in Appendices C and D.

STEP-BY-STEP CONSTRUCTION

Please note that the following construction guide has been updated since the original publication (updated December, 2023). Figure 1 depicts the foam floats constructed as a base and lid to the Pelican case. We have since adopted the ‘bucket top’ design, which utilizes a 3.5 gallon bucket to create a floatation bulkhead that the Pelican case rests atop. The bucket has a handle built-in and can be fitted with a threaded lid for added protection from seawater intrusion.

Main body

1. Use a 4” hole saw drill bit to drill three sets of two holes around the side of the 19 L plastic water bottle. These will be used to install the funnels.
 - Drill four small holes around each of the 4” holes. These smaller holes will be used to zip-tie the funnels into place.
2. Use a 4” hole saw drill bit to drill a hole in the center of the bottom of the plastic bottle (top of the trap). This hole will be used to insert the lighting unit into the top of the trap.
3. Cut a small section of 3” PVC (roughly 3” length) to be used as a connector between a PVC or ABS toilet flange and a 3” PVC or ABS slip fitting female adapter.
 - Use the appropriate PVC/ABS cement to glue the connector into the toilet flange and into the ABS slip fitting female adapter.
4. Bolt the PVC or ABS toilet flange to the bottom of the trap, making and using plastic washers as needed.
5. Drill two small holes on either side of the small openings of the 4” funnels.
 - Install small zip-ties across the small opening of the funnels to reduce the size of organisms capable of swimming into the trap.
6. Check the length of the funnel ends inside the trap to ensure the lighting unit will not sit flush against them, preventing organisms from entering the trap. Trim ends if needed.
7. Drill four small holes around the large openings of the 4” funnels that match the four small holes in the body of the trap.
 - Use these holes to zip-tie the funnels into the main body of the trap.
 - If there are large gaps around the funnels, apply a thin bead of clear marine caulk to ensure that they are securely attached to the trap.



Figure 4. Main body of trap with 7 – 4” holes drilled in the side and top for funnels and lighting unit installation.



Figure 5. Main body of trap with foam float attached and cod end pieces staged for assembly.

Bucket top

1. Cut a sheet of polyurethane foam into 1' diameter rounds.
2. Drill a 4" diameter hole in the center of two foam rounds.
3. Cut a 4" diameter hole in the bottom of the 3.5-gallon bucket to match the hole in the top of the trap body.
4. Drill 4 – ¼" holes in the bottom of the bucket and a matching hole pattern in the top of the trap body.
 - Secure the bucket top to the trap body with four stainless steel bolts and plastic or stainless washers.
5. Seal the washers and bolts with marine caulk or silicone on the inside of the bucket.
6. Insert 4" PVC or ABS coupling into the hole in the middle of the bucket and trap body. Ensure that the coupling is long enough to extend into the trap body slightly and above the foam rounds at least ½".
 - Caulk in place to ensure the bulkhead remains as waterproof as possible.
7. Insert two polyurethane foam rounds into the bucket top with coupling in the center.
8. Cut a piece of plastic that is the diameter of the bucket at the top of the coupling. Drill a hole in the center to allow it to fit over the coupling. Caulk in place to create a waterproof floating bulkhead.
 - The original lid to the bucket (not the threaded lid) can be used for this step.
9. Attach threaded bucket lid to top of bucket.

Cod end

1. Cut an 8" length of 3" PVC pipe and drill six 1 ⅜" holes in this length of pipe. Before drilling the holes, take into account the overlap of the PVC fittings that will be glued to either end of this length of pipe.
2. Cut a piece of 250 µm mesh screen that is roughly 7" x 7".
3. Coat the inside of the pipe with quick-set epoxy and carefully glue the mesh screen to the pipe.
4. Drill a small hole in the middle of the 3" PVC or ABS cap and install a stainless steel eye bolt with 2 hex nuts and a star lock washer. Use Loctite to lock the nuts in place.
5. Use the appropriate PVC or ABS cement to glue the 3" cap and the 3" PVC or ABS slip fitting male adapter to either end of the PVC pipe with the mesh screen.



Figure 6. Left: Inside bottom of bucket with bolts and plastic washers. Right: 4" PVC or ABS coupling caulked in place along with bolts and washers.



Figure 7. Left: Bucket top with coupling and foam rounds installed. Right: Fully assembled bucket top with Pelican case.



Figure 8. Fully assembled light trap pictured in the wild.

Light housing

1. Use a 2 ¼" hole saw drill bit to drill a hole in the bottom of the waterproof Pelican box.
 - Carefully sand around this hole to ensure that no plastic fragments interfere with the gasket on the bulkhead fitting.
2. Use channel locks and/or a pipe wrench to tightly fasten the polypropylene bulkhead fitting to either side of the waterproof box.
3. Cut a 14" - 16" length of 1" clear PVC pipe.
 - Ensure the clear PVC pipe extends below the bottom set of funnels. The length of the pipe may need to be lengthened or shortened depending on trap configuration.
4. Use PVC cement to glue the 1" PVC cap onto one end of the clear PVC pipe and the 1" PVC threaded male fitting to the other end.
5. Wrap Teflon pipe tape around the PVC threaded male fitting and screw it into the polypropylene bulkhead fitting.
 - Ensure that the fitting is fully installed as this is a potential weak point in the waterproof box.

Light unit

1. Cut two 2' lengths of LED strip lights at the marked cut lines.
2. Solder positive and negative wires to the positive and negative copper dots on the strip lights.
3. Cut a 1' length of square wooden dowel and attach the two lengths of lights to the four sides of the dowel using the adhesive tape on the back of the lights.
4. Use splice connectors to join the two negative and the two positive wires from the lights together.
 - Use electrical tape to secure the light strips to the dowel and prevent stress from being placed on the wires.
5. Wire the lights and battery to the timer using 22-18 AWG female slide terminals.
6. If heat-shrink wiring connectors were used, apply heat to the terminals and splice connectors to seal the connections.
7. Glue Velcro strips to the lighting unit lid and to the back of the timer to secure the timer to the Pelican box.



Figure 9. Light housing consisting of Pelican box, bulkhead fitting, and capped PVC pipe.



Figure 10. Light unit configuration with 12V lithium-ion battery and programmable timer.



Figure 11. Timer wiring diagram

ACKNOWLEDGEMENTS

Funding for the development of this monitoring program was provided in part by a U.S. Environmental Protection Agency, Puget Sound Partnership Implementation FY17 grant (Agreement #: PA-01J27601) and a Bureau of Indian Affairs, Rights Protection Implementation Climate Change FY17 grant. We would like to thank Swinomish Indian Tribal Community Fisheries Manager, L. Loomis, for providing support throughout this effort. We would also like to thank A. Shanks, E. Brown, N. Jefferson, K. Mueller and R. Rose for their invaluable guidance, and J. Sones for the Dungeness crab instar photograph. Finally, a special thank you to S. George, K. Hale, T. Harrah, S. Hoh, T. Flannagan, J. Flowers, J. Nevitt, and H. Rooks for help refining volunteer monitoring protocols.

REFERENCES

- Baylor ER, Smith FE (1953) A physiological light trap. *Ecology* 34:223–224
- Cowen RK, Sponaugle S (2009) Larval dispersal and marine population connectivity. *Ann Rev Mar Sci* 1:443–466
- DeBrosse GA, Baldinger AJ, McLaughlin PA (1989) A comparative study of the megalopal stages of *Cancer oregonensis* Dana and *C. productus* Randall (Decapoda: Brachyura: Cancridae) from the northeastern Pacific. *Fish Bull* 88:39–49
- DeBrosse G, Sulkin S, Jamieson G (1990) Intraspecific morphological variability in megalopae of three sympatric species of the genus cancer (Brachyura: Cancridae). *J Crust Biol* 10:315–329
- Dinnel PA, Armstrong DA, McMillan RO (1993) Evidence for multiple recruitment-cohorts of Puget Sound Dungeness crab, *Cancer magister*. *Mar Biol* 115:53–63
- Doherty PJ (1987) Light-traps: selective but useful devices for quantifying the distributions and abundances of larval fishes. *Bull Mar Sci* 41:423–431
- Faber DJ (1981) A light trap to sample littoral and limnetic regions of lakes. *SIL Proceedings, 1922-2010* 21:776–781
- Gregory RS, Powles PM (1985) Chronology, distribution, and sizes of larval fish sampled by light traps in macrophytic Chemung Lake. *Can J Zool* 63:2569–2577
- Herter H, Eckert GL (2008) Transport of Dungeness crab *Cancer magister* megalopae into Glacier Bay, Alaska. *Mar Ecol Prog Ser* 372:181–194
- Hickford MJH, Schiel DR (1999) Evaluation of the performance of light traps for sampling fish larvae in inshore temperate waters. *Mar Ecol Prog Ser* 186:293–302
- Hungerford HB, Spangler PJ, Walker NA (1955) Subaquatic light traps for insects and other animal organisms. *Trans Kans Ac Sci* (1903-) 58:387–407
- Jackson TM, O'Malley KG (2017) Comparing genetic connectivity among Dungeness crab (*Cancer magister*) inhabiting Puget Sound and coastal Washington. *Mar Biol* 164:123
- McLeod LE, Costello MJ (2017) Light traps for sampling marine biodiversity. *Helgol Mar Res* 71:2
- Meekan M, Wilson S, Halford A, Retzel A (2001) A comparison of catches of fishes and invertebrates by two light trap designs, in tropical NW Australia. *Mar Biol* 139:373–381
- Miller JA, Shanks AL (2004) Ocean-estuary coupling in the Oregon upwelling region: abundance and transport of juvenile fish and of crab megalopae. *Mar Ecol Prog Ser* 271:267–279
- Pineda J (1994) Internal tidal bores in the nearshore: Warm-water fronts, seaward gravity currents and the onshore transport of neustonic larvae. *J Mar Res* 52:427–458
- Pineda J, Porri F, Starczak V, Blythe J (2010) Causes of decoupling between larval supply and settlement and consequences for understanding recruitment and population connectivity. *J Exp Mar Bio Ecol* 392:9–21
- Poole RL (1966) A description of laboratory-reared zoeae of *Cancer magister* Dana, and megalopae taken under natural conditions (Decapoda Brachyura). *Crustaceana* 11:83–97
- Porter SS, Eckert GL, Byron CJ, Fisher JL (2008) Comparison of light traps and plankton tows for sampling brachyuran crab larvae in an Alaskan fjord. *J Crust Biol* 28:175–179
- Roegner GC, Armstrong DA, Hickey BM, Shanks AL (2003) Ocean distribution of Dungeness crab megalopae and recruitment patterns to estuaries in southern Washington State. *Estuaries* 26:1058–1070
- Roegner GC, Armstrong DA, Shanks AL (2007) Wind and tidal influences on larval crab recruitment to an Oregon estuary. *Mar Ecol Prog Ser* 351:177–188

- Shanks AL (1983) Surface slicks associated with tidally forced internal waves may transport pelagic larvae of benthic invertebrates and fishes shoreward. *Mar Ecol Prog Ser* 13:311–315
- Shanks AL (2001) An identification guide to the larval marine invertebrates of the Pacific Northwest. Oregon State University Press
- Shanks AL (2013) Atmospheric forcing drives recruitment variation in the Dungeness crab (*Cancer magister*), revisited. *Fisheries Oceanogr* 22:263–272
- Shanks AL, Roegner GC (2007) Recruitment limitation in Dungeness crab populations is driven by variation in atmospheric forcing. *Ecology* 88:1726–1737
- Shanks AL, Roegner GC, Miller J (2010) Using megalopae abundance to predict future commercial catches of Dungeness crab (*Cancer magister*) in Oregon. *Cal Coop Ocean Fish Inv Rep* 51:106–118
- Sigurdsson GM, Rochette R, Morse B (2014) Light traps as a tool to sample pelagic larvae of American lobster (*Homarus americanus*). *J Crust Biol* 34:182–188

APPENDIX A: List of materials

Main body		'Bucket top' floatation	
1	5 gallon plastic water bottle	1	3.5 gallon plastic bucket
6	4" funnel	1	Threaded bucket lid
24	Small zip ties	2	1.5" or 2" Polyurethane foam insulation, cut into rounds
1	3" / 4" PVC or ABS toilet flange	1	4" PVC segment to create waterproof bulkhead
1	3" PVC or ABS slip fitting female adapter	1	Plastic round cut to create waterproof bulkhead
1	4" PVC coupling		
Light unit		Light housing	
2	2' waterproof white LED strip lights 60 LEDs/m	1	14-16" length of 1" clear PVC schedule 40 pipe
1	½" x 12" square dowel	1	PVC cap – socket, 1" pipe size
1	2' length of 22-18 AWG speaker wire	1	1" socket connect female x threaded NPT male fitting
4	22-18 AWG heat shrink butt splice connectors	1	Pelican 1120 protector case with foam
4	22-18 AWG heat shrink female slide terminals	1	Polypropylene bulkhead fitting – 1" X 2 ¼"
1	Programmable timer with 12V DC switch	1	Velcro to attach timer to inside lid of Pelican case
1	Talentcell 12V rechargeable battery 11,000 mAh		
Cod end		Hardware	
1	3" PVC or ABS slip fitting male adapter	8	¼" x 1 ½" stainless steel hex cap bolts
1	3" PVC pipe, cut to roughly 8" length	8	¼" stainless steel flat washers
1	3" PVC cap	8	¼" stainless steel hex nuts
1	250 micron nylon mesh screen, cut to size	1	3/16" x 2" stainless steel eye bolt, nuts, & lock washers
Tools		Adhesives	
1	4" hole saw	1	Electrical tape to secure light strips to dowel
1	2-1/4" hole saw	1	Teflon pipe tape
1	1-3/8" hole saw	1	Sikaflex clear marine caulk
1	Drill with small drill bits	1	ABS/PVC cement
1	Soldering iron	1	PVC primer and solvent cement
1	Wire stripper and crimper	1	Quick-set epoxy
1	Heat gun	1	Loctite
2	Pipe wrench or channel locks		
Mooring			
1	Self-coiling braided steel security cable – 6'		
2	Stainless steel carabiner		
1	Length of line – site specific		
1	2-5 lb. canon ball weight with carabiner		

APPENDIX B: Light trap monitoring datasheet

LIGHT TRAP MONITORING DATASHEET

Light Trap Site Information							
Site:							
Date	Time	Samplers	Battery Level	Hours Fished	Weather	Photo	Timer Setting
1					C OC PC R	<input type="checkbox"/>	Start Time:
2					C OC PC R	<input type="checkbox"/>	
3					C OC PC R	<input type="checkbox"/>	End Time:
4					C OC PC R	<input type="checkbox"/>	
Dungeness Crab Catch (Required)							
Sample Processing	¹ <input type="checkbox"/> Fresh <input type="checkbox"/> Frozen	² <input type="checkbox"/> Fresh <input type="checkbox"/> Frozen	³ <input type="checkbox"/> Fresh <input type="checkbox"/> Frozen	⁴ <input type="checkbox"/> Fresh <input type="checkbox"/> Frozen			
Total Dungeness Megalopae							
Total Dungeness Instars							
Other Species Catch (Optional)							
Sample Processing	¹ <input type="checkbox"/> Fresh <input type="checkbox"/> Frozen	² <input type="checkbox"/> Fresh <input type="checkbox"/> Frozen	³ <input type="checkbox"/> Fresh <input type="checkbox"/> Frozen	⁴ <input type="checkbox"/> Fresh <input type="checkbox"/> Frozen			
Pagurus Megalopae	<input type="checkbox"/>	<input type="checkbox"/>	<input type="checkbox"/>	<input type="checkbox"/>			
O.U. Megalopae 1							
O.U. Megalopae 2							
O.U. Megalopae 3							
O.U. Instars 1							
O.U. Zoea	P F S M A	P F S M A	P F S M A	P F S M A	P F S M A		
Forage Fish	P F S M A	P F S M A	P F S M A	P F S M A	P F S M A		
Salmon	P F S M A	P F S M A	P F S M A	P F S M A	P F S M A		
Gunnel	P F S M A	P F S M A	P F S M A	P F S M A	P F S M A		
Sculpin	P F S M A	P F S M A	P F S M A	P F S M A	P F S M A		
Flatfish	P F S M A	P F S M A	P F S M A	P F S M A	P F S M A		
Bay Pipefish	P F S M A	P F S M A	P F S M A	P F S M A	P F S M A		
O.U. Fish ID reverse	P F S M A	P F S M A	P F S M A	P F S M A	P F S M A		
Amphipod	P F S M A	P F S M A	P F S M A	P F S M A	P F S M A		
Isopod:	<input type="checkbox"/> kelp <input type="checkbox"/> pill bug	<input type="checkbox"/> kelp <input type="checkbox"/> pill bug	<input type="checkbox"/> kelp <input type="checkbox"/> pill bug	<input type="checkbox"/> kelp <input type="checkbox"/> pill bug	<input type="checkbox"/> kelp <input type="checkbox"/> pill bug		
Cephalopod	P F S M A	P F S M A	P F S M A	P F S M A	P F S M A		
Polychaete	P F S M A	P F S M A	P F S M A	P F S M A	P F S M A		
Shrimp	P F S M A	P F S M A	P F S M A	P F S M A	P F S M A		
O.U. #1 ID Reverse							
O.U. #2							
O.U. #3							
O.U. #4							

Abundance codes: P (1-3) F (3-10) S (10-50) M (50-100) A (100+)

*Specimen Collected

* Preserved Sample: Weather: C = Clear. OC = Overcast. PC = Partlv Cloudv. R = Rain

Data Entrv Complete:

LIGHT TRAP MONITORING DATASHEET

Estimate Species Abundance via Subsampling								
Date	Species	Total Volume	Subsample Volume	Subsample Count				Total Count
				Count 1	Count 2	Count 3	Avg Count	

Subsample Volume = volume of sample examined e.g. 200 mL, Total Sample Volume = volume of the entire sample e.g. 1000 mL;
 Total Count = (Average Subsample Count/Subsample Volume) x Total Sample Vol

Daily Identification of O.U. Species (reference reverse page)				
Date	O.U. ID	Stage	Species ID	Notes
		<input type="checkbox"/> Meg <input type="checkbox"/> Ins		<input type="checkbox"/>
		<input type="checkbox"/> Meg <input type="checkbox"/> Ins		<input type="checkbox"/>
		<input type="checkbox"/> Meg <input type="checkbox"/> Ins		<input type="checkbox"/>
		<input type="checkbox"/> Meg <input type="checkbox"/> Ins		<input type="checkbox"/>
		<input type="checkbox"/> Meg <input type="checkbox"/> Ins		<input type="checkbox"/>
		<input type="checkbox"/> Meg <input type="checkbox"/> Ins		<input type="checkbox"/>
		<input type="checkbox"/> Meg <input type="checkbox"/> Ins		<input type="checkbox"/>
		<input type="checkbox"/> Meg <input type="checkbox"/> Ins		<input type="checkbox"/>
		<input type="checkbox"/> Meg <input type="checkbox"/> Ins		<input type="checkbox"/>

Notes

Data Entry Complete: _____

APPENDIX C: Citizen scientist step-by-step guide



LARVAL DUNGENESS CRAB MONITORING Step-by-Step Guide

Welcome!

The Swinomish Indian Tribal Community (SITC) is using light traps to study the larval abundance of Dungeness crab in northern Puget Sound waters. Light traps are moored from docks and use LED lights to attract larval stages of crab, otherwise known as megalopae. As a citizen scientist volunteer, you will adopt a light trap and regularly collect larval crab samples throughout the Dungeness crab recruitment period (April to September). Thank you for your work to help study this critically important species!

MATERIALS LIST:

- Clipboard with Light Trap Report forms
- Trap ID photo card
- Dish tubs
- Sample jars
- Spoons
- Water bottle
- Charged battery
- "Save a trap" kit

LIGHT TRAP DIAGRAM

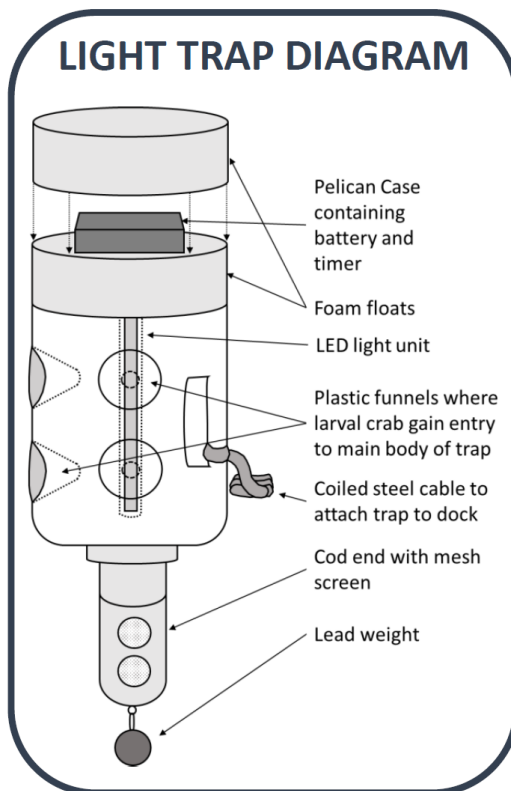

RETRIEVING TRAP

1. Unhook the carabiner that attaches the coiled steel cable to the dock.
2. Pull the trap from the water using the rope handle and allow the water to drain through the mesh screen on the cod end.
3. Unclip the weight from the cod end.
4. Remove the foam lid from the top of the trap.
5. Detach the nylon straps from the Pelican case and pull it from the trap, set aside.
6. Pour some water into the main body of the trap to ensure that all the contents have been emptied into the cod end.
7. Unscrew the cod end and dump the contents into the tub.
8. Use the water bottle and/or spoon to rinse any remaining contents from the cod end.

QUESTIONS OR CONCERNS?

Contact Claire Cook at (360) 391-3652 or ccook@swinomish.nsn.us and/or Sarah Grossman at (360) 708-3516 or sgrossman@swinomish.nsn.us

PROCESSING SAMPLE

1. Fill out the trap ID photo card with the site name and date. Place it beside the tub and take a picture of the tub contents with the photo card visible.
2. Use a slotted spoon to remove fish from the sample.
 - Be careful not to discard any Dungeness crab megalopae or instars!
3. Collect the megalopae and instars in a jar labeled with the site name, date, and number of jars collected - in case you use multiple jars.
 - If the sample is very full and/or you are unable to confidently identify the Dungeness crab megalopae, simply pour the entire sample into labeled jars.
4. Record the date, the time the trap was retrieved, whether or not megalopae were present, and whether or not sample jars and photos were collected on the Light Trap Report.
5. Return the rest of the critters to the water.

DUNGENESS CRAB MEGALOPAE

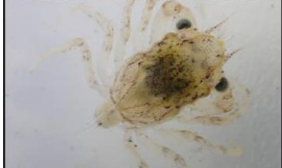

3-4 mm width



DUNGENESS CRAB INSTAR

5-7 mm width

CHANGING BATTERY



1. Unstrap and open the Pelican case, and unplug the battery.
2. Record the level of charge remaining by noting the number of green dots illuminated on the side of the battery.
3. Plug in the new, fully-charged battery and turn it on.
 - Double check that the battery is loaded into the Pelican case as it is in the image to the left.
6. Close the Pelican case and strap it back onto the trap.

DEPLOYING TRAP

1. Reattach the cod end to the main body of the trap.
2. Strap the foam float to the top of the trap and clip the weight to the eye bolt on the cod end.
3. Lower the trap back into the water, loop the coiled steel cable around the dock and clip it to itself with the carabiner.
4. Record the time that the trap was redeployed and note any comments or issues from your visit.
5. Take the labeled sample jars home and put them in the freezer.
6. Be sure to email the picture of the tub contents with the sample label AND the Light Trap Report to Claire at ccook@swinomish.nsn.us.

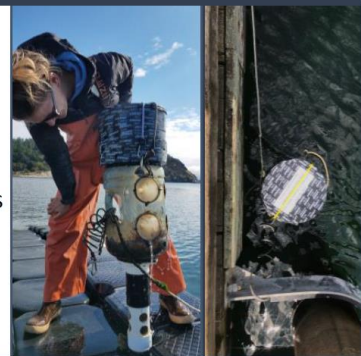

Don't forget to plug the battery in when you get home!

SUBMITTING DATA

Please submit Light Trap Reports and images of trap contents within one week of sampling! SITC staff will collect frozen sample jars every 3-4.

APPENDIX D: Citizen scientist light trap report

 <p>SWINOMISH INDIAN TRIBAL COMMUNITY</p>	<p>LARVAL DUNGENESS CRAB MONITORING Light Trap Report</p>
---	---

Site Name: _____ Date: _____

Volunteer Names: _____

Retrieval Time: _____ Time Deployed: _____

WEATHER	SUNNY	PARTLY CLOUDY	OVERCAST	RAIN
----------------	--------------	----------------------	-----------------	-------------

MEGALOPAE PRESENT	YES	NO	JAR COLLECTED	YES	NO	JAR LABEL	
	<input type="checkbox"/>	<input type="checkbox"/>		<input type="checkbox"/>	<input type="checkbox"/>		

Comments:

BATTERY CHARGE LEVEL: # DOTS LIT / TOTAL DOTS	
--	--

Fill out the laminated trap ID photo card with the site name and date using the grease pen provided. Place it beside the tub and take a picture of the tub contents with the trap ID card visible.

PICTURE TAKEN	YES	NO
	<input type="checkbox"/>	<input type="checkbox"/>



Please submit this report and photograph to Claire Cook at ccook@swinomish.nsn.us within one week of your visit! Staff will collect frozen sample jars every 3-4 weeks.